

4000 AT-S/M/L

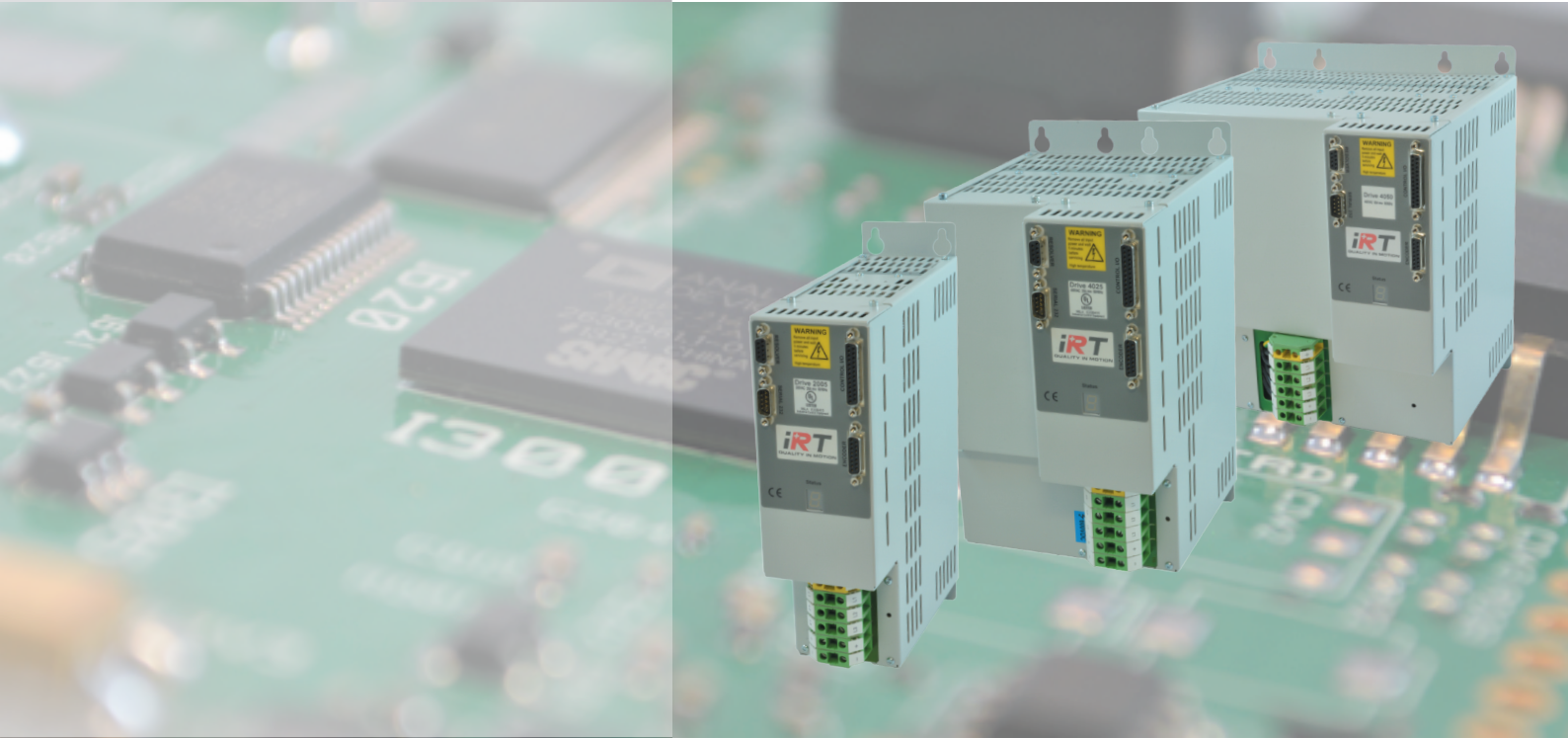

Technical Manual





UL Requirements Drives Series 2000 / 4000 AT

1. Field wiring terminal to use 60/75 or 75°C copper (CU) wire only.
2. Input power terminal tightening torque = 1.2 Nm
3. Motor terminal tightening torque = 0.5 Nm
4. No overspeed protection incorporated
5. Degree of overload protection provided internally by the drive, in percent of full load current or current value.
6. Open chassis to be installed in an enclosure that protects the drive from conductive dust and condensation (pollution degree 2 environment).
7. Maximum surrounding air temperature = 40 degree C.
8. These devices are not provided with motor overtemperature sensing.
9. Integral solid state short circuit protection does not provide branch circuit protection. Branch circuit protection must be provided in accordance with the National Electrical Code and any additional local codes.
10. Suitable for use on A circuit capable of delivering not more than 5000 rms - symmetrical amperes, 230 (2000 Serie) and 400 (4000 Serie) Volts maximum. The short circuit ampere rating and the fuse ampere rating shall be in accordance with the following rating table :

Drive Model	Branch Fuses	
	Ratings	Reference
4003	30A – 690V (rated I^2t 815)	Ferraz Shawmut, JFHR2 – type A070GRB 30E113, 10,3 x 38 (reference M330015)
4005		
4009		
2005		
2010		
2020	50A – 690V (rated I^2t 2250)	Ferraz Shawmut, JFHR2 – type 6.900 CP gRC, 14.51 x 50 (reference L220902)
4015		
4025		
4050	100A / 690V (rated I^2t 11950)	Ferraz Shawmut, JFHR2 – type 6.900 CP gRC, 22.58 x 100 (reference W220911)

UL listed drives : 2000 S-AT 4000 S-AT 4000 M-AT 4000 L-AT

Contents

CHAPTER A - DESCRIPTION AND TECHNICAL DATA	4
1. INTRODUCTION	4
2. DESCRIPTION	5
3. TECHNICAL DATA	7
3.1 GENERAL DATA FOR ALL TYPES	7
3.2 ELECTRICAL DATA	8
3.2.1 INRUSH CURRENT	9
3.3 DRIVES AT OUTLINES	10
3.3.1 SMALL AT DRIVE OUTLINES	10
3.3.2 MEDIUM AT DRIVE OUTLINES	11
3.3.3 LARGE AT DRIVE OUTLINES	12
3.4 MOTORS	13
3.5 POSITION FEEDBACK	13
4. FUSES	14
5. OPTION LIST	14
6. ADD-ON BOARDS	15

CHAPTER A - DESCRIPTION AND TECHNICAL DATA

1. Introduction

The servo-amplifiers serie 4000 AT are intended for the control of 3 phases brushless servo-motors and asynchronous servo-motors.

The motors regulated by the serie 4000 AT servo-amplifiers should have the following characteristics:

- Rotor constructed with permanent magnets or winding cage arranged in 1, 2, 3, 4, 5 or 6 pole pairs, without commutator.
- Stator constructed with 3 windings connected in star or delta.
- Brushless motors : electronic commutation is performed by means of a feedback type :
 - **Speed one resolver**
 - **Absolute encoder SinCos Hiperface compatible**
 - **Incremental encoder with U, V and W signals**
 - **EnDat.**
- Asynchronous motors : electronic commutation is only performed by means of a feedback type :
 - **Speed one resolver**
 - **Incremental encoder.**
- Motors with Hall effect sensors and tachogenerator are not suitable.

The servo-amplifier serie 4000 AT are fully digital. High-performance torque, speed and positioning control fulfils all requirements for rapid response and control accuracy.

Digital control allows comprehensive diagnostics, motor parameters tuning, data and fault logging, etc.. using a PC based user program.

A wide range of firmware assures to meet the requirements of practically any application.

2. Description

The particular features of the servo-amplifiers serie 4000 AT are described thereunder:

Power supply

- Single-Axis unit incorporating braking module for connection to 3 phases power supply. Possibility to connect the drives to a common DC-bus voltage.
- Direct 400V three-phase main supply.
- Option: Internal filters in power source reducing noise emission.

Power driver

- Galvanic isolation between control and power electronics.
- IGBT output stage.
- Digital PWM current loop providing very low ripple motor currents and high motor efficiency.

Digital controller

- Full-digital servo-amplifier for Brushless motor with resolver.
- Easy software update and fully programmable through serial link RS232 or RS485.
- Possibility to integrate a customised *INTERFACE* board.
- Energy managing system for fan-cooling.
- Multi loops control (torque and speed).
- Sinusoidal current output ensures smooth torque and optimal performance at low speed.
- 7 segment status indicator for diagnostic display.

User's inputs

- Analogue speed or current input command +/- 10V or digital input command.
- RS232 serial port and RS485 serial port for multi axis controller system.
- Limit switches for overrun protection in both directions.
- External power supply to the Control and Interface boards to keep position data and alarms in case of main power supply interruption.

User's outputs

- Incremental encoder output simulation with adjustable resolution from 1 to 1024 ppr and adjustable marker pulse. Differential line driver outputs.
- Ready relay contact.

Protections

- Protection and rugged construction for use in adverse conditions.
- Power stage fully protected against short-circuit and over-temperature.
- Motor protection by I^2t limitation.
- Detection of resolver fault, motor wiring failure, motor overheating.

3. Technical data

3.1 General data for all types

Description		Unit	4000 AT Serie
Supply frequency		Hz	45 to 65
Operating temperature range		° C	0 to 60
Operating temperature range at full power (from 45°C, reduce output current by 2%/°C to 60°C)		° C	0 to 45
Storage temperature range		°C	-25 to +55
PWM chopper frequency		kHz	7.5
Differential input reference		V	+ 10 to -10
Speed control range			1/32768
Speed loop bandwidth		Hz	max. 150
Current loop bandwidth		Hz	max. 2000
Output frequency to motor		Hz	0 to 500
Incremental encoder simulation		ppr	1 to 1024 (2048)
Theoretical max. speed for motor with resolver "speed one"		rpm	7500 or 12000 depending on firmware version
Serial link	Standard baud rate	Bd.	9600
	Transmission		Full duplex
	Format		1 START bit, 8 DATAS bit, no parity, 1 STOP bit
Time between power on and enable drive		sec	Max. 3
International Protection			IP20
Supply Voltage		VAC	3x400 +10% -20%
Max. output voltage to motor		V	3 x 390
ON-Switching threshold of brake module		VDC	670
OFF-Switching threshold of brake module		VDC	660
ON-Trip threshold of overvoltage		VDC	710
OFF-Trip threshold of overvoltage		VDC	690
OFF-Trip threshold of undervoltage		VDC	395
ON-Trip threshold of undervoltage		VDC	380
Cooling			Natural air convection Air fan forced over 40°C
Indicative weight :		kg	
Small AT			3.3
Medium AT			6.2
Large AT			10,5

3.2 Electrical data

Drive AT Type		Rated rms current ($I_{rms \text{ rated}}$) (A)	Rated pk. current ($I_{peak \text{ rated}}$) (A)	Max. rms current ($I_{rms \text{ max}}$) (A)	Max. peak current ($I_{peak \text{ max}}$) (A)	Rated power (P_{rated}) (kW)	Max. power (P_{max}) (kW)
Small	4003	3	4	6	8.5	2	4
	4005	5	7	10	14	3.5	7
	4009	9	13	18	25	6	12
Medium	4015	15	21	30	42	10	20
	4025	25	35	50	70	17	34
Large	4050	50	70	100	140	34	68

Note: $I_{rms} = I_{peak} / 1,41$ $V_{rms} = 390V$
 $P = 1,73 \times I_{rms} \times V_{rms}$ or $P = 3 \times I_{rms/phase} \times V_{rms/phase}$

Braking power :

Drive AT type		$R_{braking}$ (Ω)	Peak braking power (kW)	Max. continuous braking power (W)	Surge energy ($\Delta T=300K$) (kJ)
Small	4003	60	7.5	250	5
	4005	60	7.5	250	5
	4009	60	7.5	250	5
Medium	4015	30	15	500	10
	4025	16.5	27	500	15
Large	4050	11	40	1000	22

The surge energy rating is the maximum permitted dynamic brake application from cold. To a first approximation, heat is then removed at the rate given by the continuous power figure : thus about 20 seconds interval must be allowed between full energy stops.

3.2.1 Inrush current

Wave shape for the nominal values

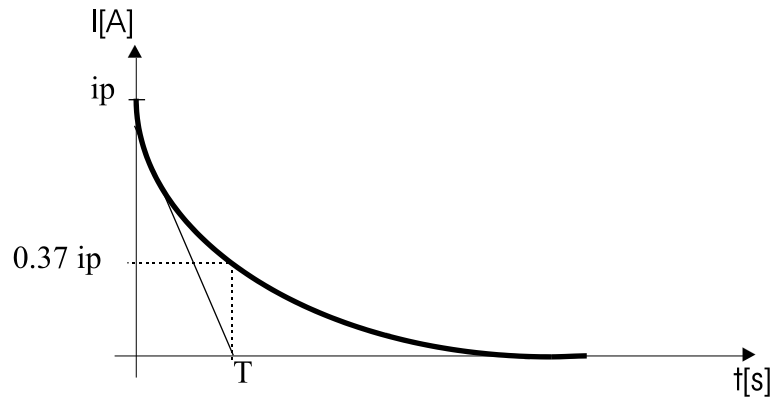

$$i(t) = i_p \cdot e^{-t/T} \quad \Rightarrow \quad i^2 \cdot t = \frac{1}{2} \cdot i_p^2 \cdot T$$

Inrush current i_p :

Small 4003, 4005, 4009 AT:

$$i_p = 9.3 \text{ A} \quad \text{and} \quad T = 14 \text{ ms} \quad \Rightarrow \quad i^2 t = 0.6 \text{ A}^2 \text{ s}$$

Medium 4015 AT:

$$i_p = 18.7 \text{ A} \quad \text{and} \quad T = 21 \text{ ms} \quad \Rightarrow \quad i^2 t = 3.7 \text{ A}^2 \text{ s}$$

Medium 4025 AT:

$$i_p = 34 \text{ A} \quad \text{and} \quad T = 11.5 \text{ ms} \quad \Rightarrow \quad i^2 t = 6.7 \text{ A}^2 \text{ s}$$

Large 4050 AT:

$$i_p = 51 \text{ A} \quad \text{and} \quad T = 10.3 \text{ ms} \quad \Rightarrow \quad i^2 t = 13.4 \text{ A}^2 \text{ s}$$

3.3 Drives AT outlines

3.3.1 Small AT drive outlines

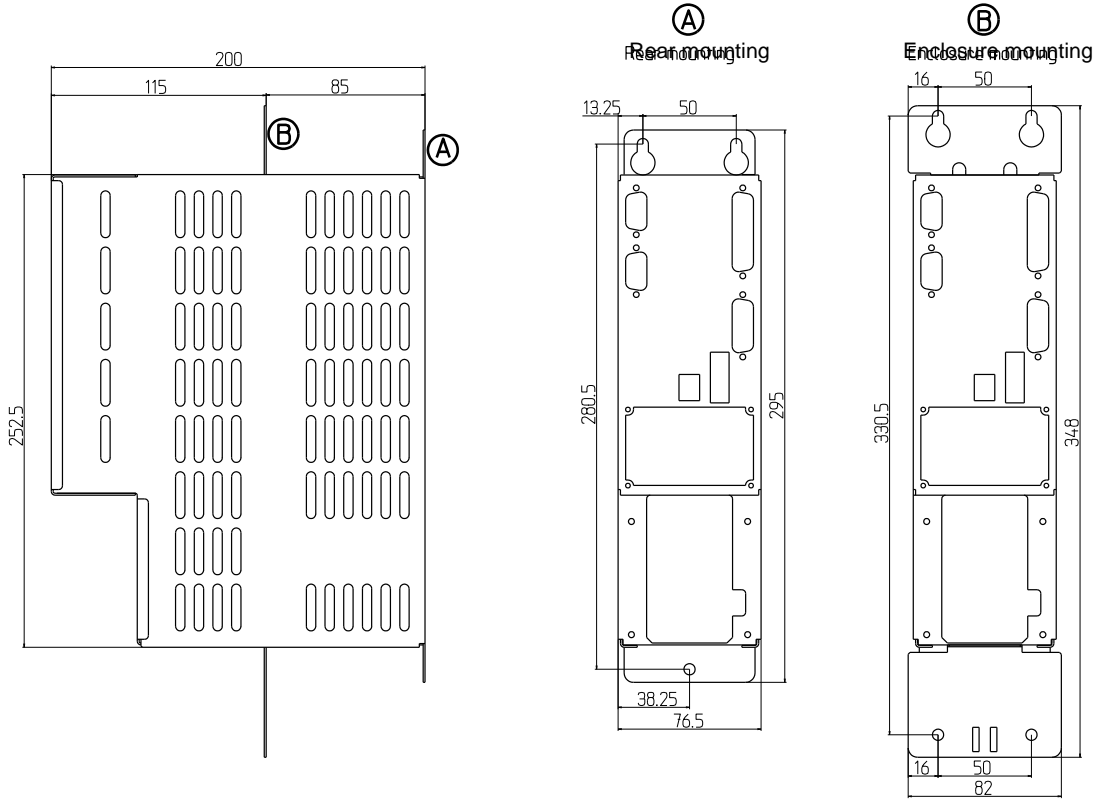

Installation, drill and cutout plan :

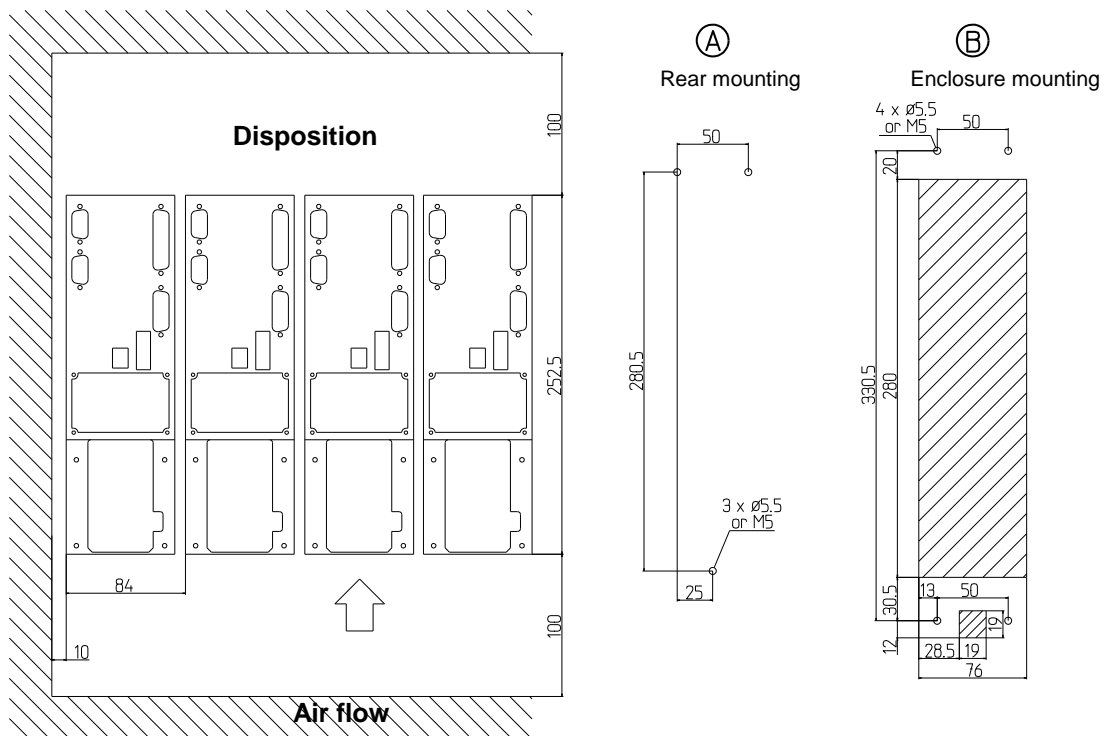

3.3.2 Medium AT drive outlines

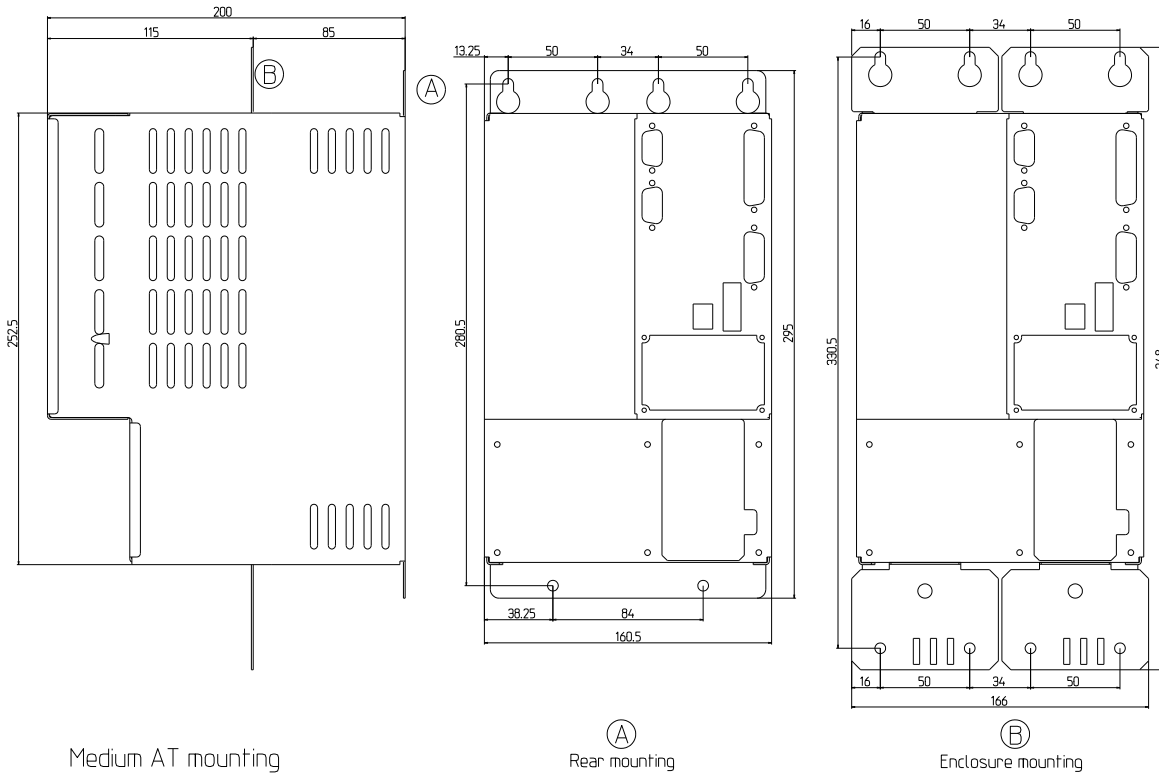

Installation, drill and cutout plan :

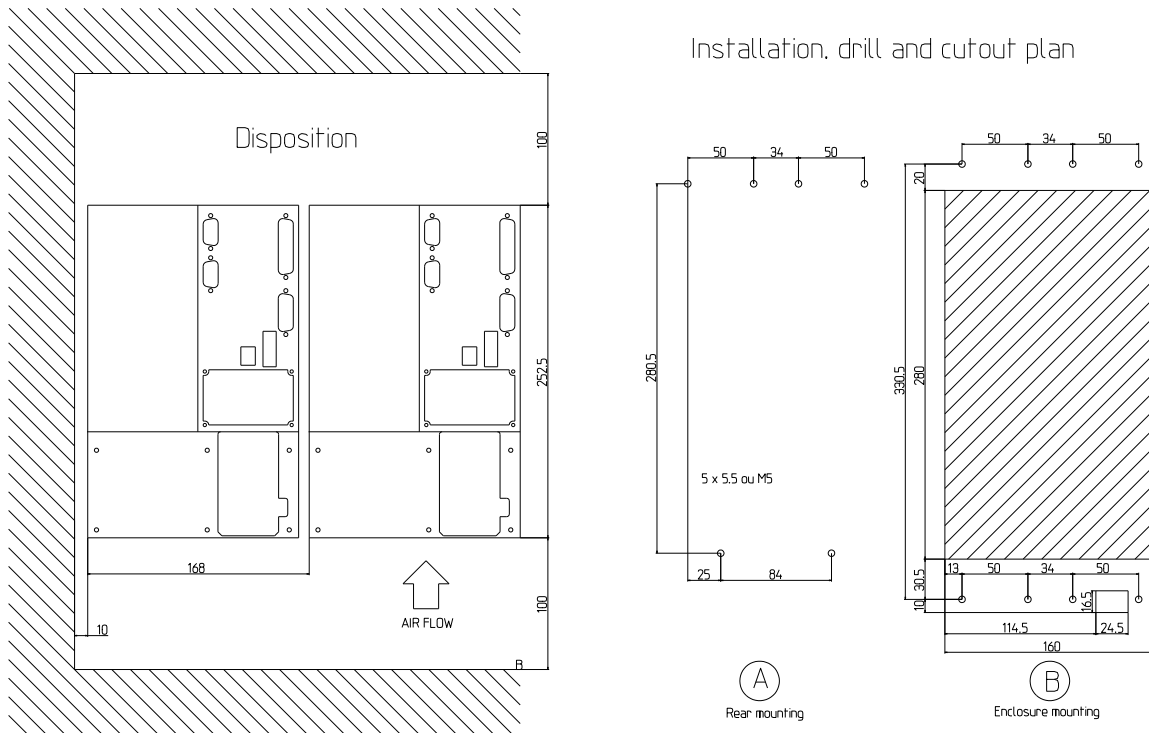

3.3.3 Large AT drive outlines

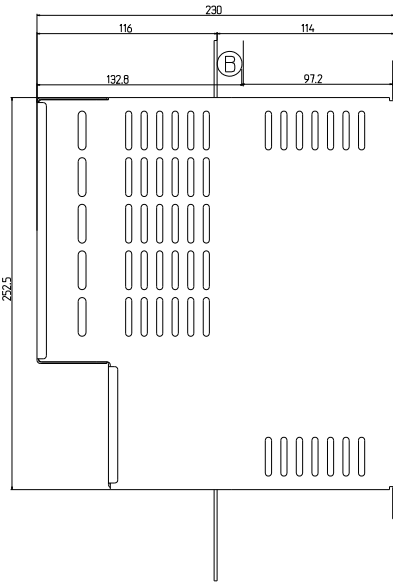

Large AT mounting

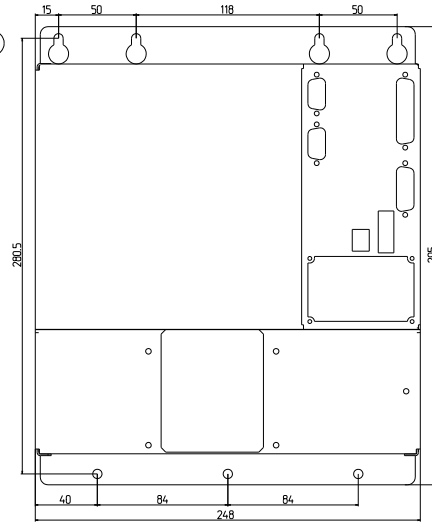

Ⓐ Rear mounting

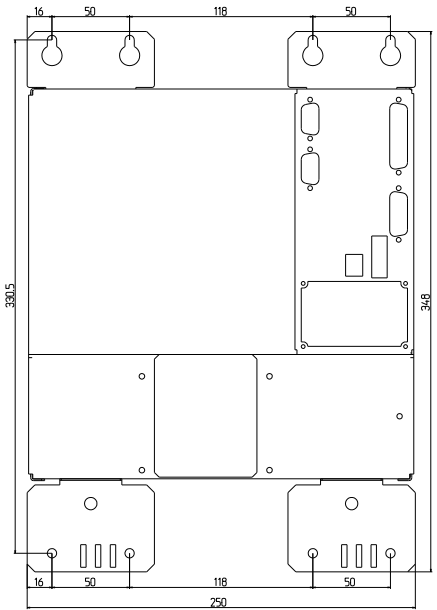

Ⓑ Enclosure mounting

Installation, drill and cutout plan :

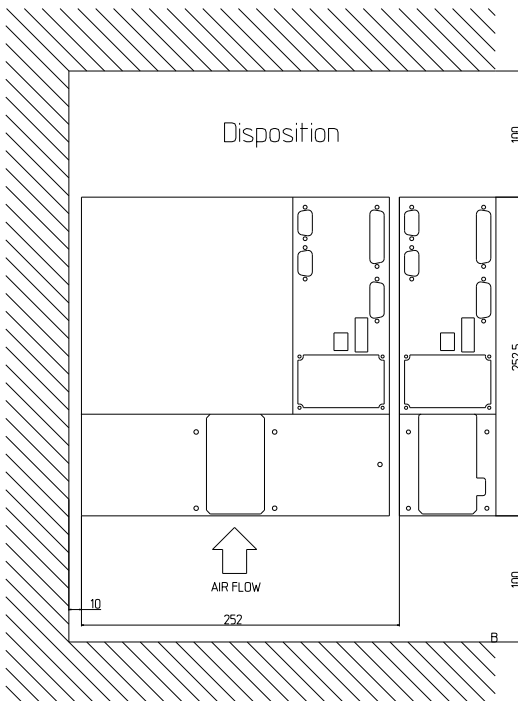

Installation, drill and cutout plan

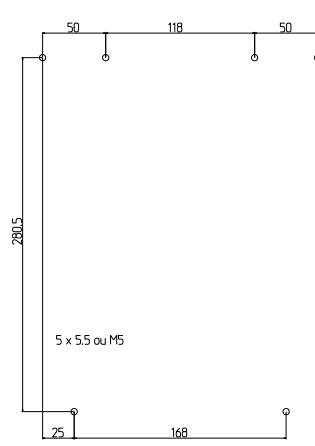

Ⓐ Rear mounting

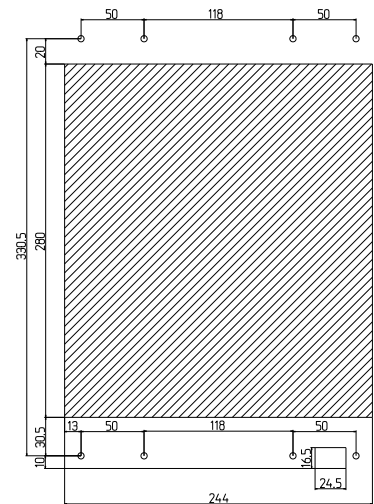

Ⓑ Enclosure mounting

3.4 Motors

- Brushless 3 phases servo-motors
- Asynchronous, 3 phases motors

3.5 Position feedback

- Resolver :

Characteristics :

- Speed One (1 sine period and 1 cosine period per revolution)
- Ratio $0.5 \pm 10\%$
- Reference frequency : 5..10 kHz
- $Z_{RO} > 95\Omega$ @ 7,5 kHz (Input impedance)
- $Z_{SO} < 1000\Omega$ @ 7,5 kHz (Output impedance)

- Incremental encoder for asynchronous motor only.
- Absolute encoder Stegmann SinCos Multi and Single turn SRS/M 50/60(HIPERFACE compatible).
- Incremental encoder with U, V and W signals for synchronous motor.
- EnDat encoder.

4. Fuses

The following fuses are factory equipped in all units of the series 4000 :

Drive Type AT		DC-BUS (FBUS)
Small	4003 , 4005, 4009	30A gRB/690V 10.3x38 Ferraz, art. A070 gRB 30T13 <i>UL: E76491</i> Art. IRT: 2410.159.30
Medium	4015, 4025	50A gRC/690V 14x51 Ferraz, art. L220902 <i>UL: E76491</i> Art. IRT: 2410.160.50
Large	4050	100A URB/690V 17x49 Ferraz, art. C220986 <i>UL: E76491</i> Art. IRT: 2410.163.100

NB : No replacement of any fuse should be carried out until the reason for it's blowing has been rectified.

5. Option list

1. EMC FILTER ON 3 PHASES INPUT SUPPLY (Small AT only)
2. MECHANICAL MOTOR BRAKE RELAY
3. RS485 BUS
4. AUXILIARY 24V SUPPLY

6. Add-on boards

Add-on boards compatible with series 2000 Small drives

IRT PROFILE

Add-on board to perform simple movements and interfacing with 24V systems (PLS).

Main characteristics :

- 24 V powered.
- DC-DC conversion for drive power back-up (the position value is kept when main supply of the drive is switched off).
- 14 Outputs potential free (24V 100 mA).
- 16 Inputs 24V potential free.
- Windows Profile User software for easy setting.

To obtain more information about Profile board, contact your IRT distributor.

Distributed by :

Official IRT distributors.

UVW ENCODER FEEDBACK

See Special functions specification.

Distributed by :

Official IRT distributors.

Dual analogic bipolar output

Outputs range : +/- 10V

Output SPEED : 1V corresponds to 1000 RPM

Output CURRENT : 10V corresponds to $I_{MAX DRIVE}$

Distributed by :

Official IRT distributors.

Add-on boards compatible with series 2000 Small drives

☐ MKS IR115 / IR116 / IR117

Synchro-Control, positioning and CANopen interface module for IRT Series 2000 Small drives.

Manufacturer :

MKS Mashinen-Kontroll-System Gmbh
Zwischen den Wegen 32
D-78239 Rielasingen 2 - Germany
Tel. +49 (0)7731-9332-0
Fax +49 (0)7731-9332-30
E-Mail info@mks-sys.com
Internet www.mks-sys.com

Distributed by :

MKS.
Official IRT distributors.

☐ QUIN SERVOnet

Positioning control and SERVOnet (CAN-BUS type) interfacing module for IRT series 2000 Small drives.

Manufacturer :

Quin Systems limited
Oakland business Centre
Oakland Park
Wokingham
Berkshire RG41 2FD
Tel 0118 977 1077
Fax 0118 977 6728
E-Mail : sales@quin.co.uk
Internet : www.quin.co.uk

Distributed by :

Quin System.

DRIVE SERIES 4000 AT, TECHNICAL MANUAL EVOLUTION

CHAPTER	PAGE (OLD VERSION)	PAGE	REVISION	DESCRIPTION
			2	Manual reduced to Technical manual for drives 4000 AT UL
	1	1	3	Image from Large Drive
3	8	8	3	Braking power new definition
	2	2	4	UL Requirements
3	10	10	4	Drives outlines, Motor + Feedback
	2	2	5	UL Requirements

Last modification : September 2013